

# INSTALLATION INSTRUCTIONS **RAD** MOTORWORKS

## RAD MOTORWORKS UNIVERSAL MSR FUEL BOTTLE / STORAGE MOUNT FOR ANY VEHECLE

Thank you for choosing RAD MOTORWORKS! This installation instructions will take you through the installation of your RAD MOTORWORKS UNIVERSAL MSR Fuel Bottle Mount compatible with ANY Vehicle.



# **RAD** MOTORWORKS

## Parts List

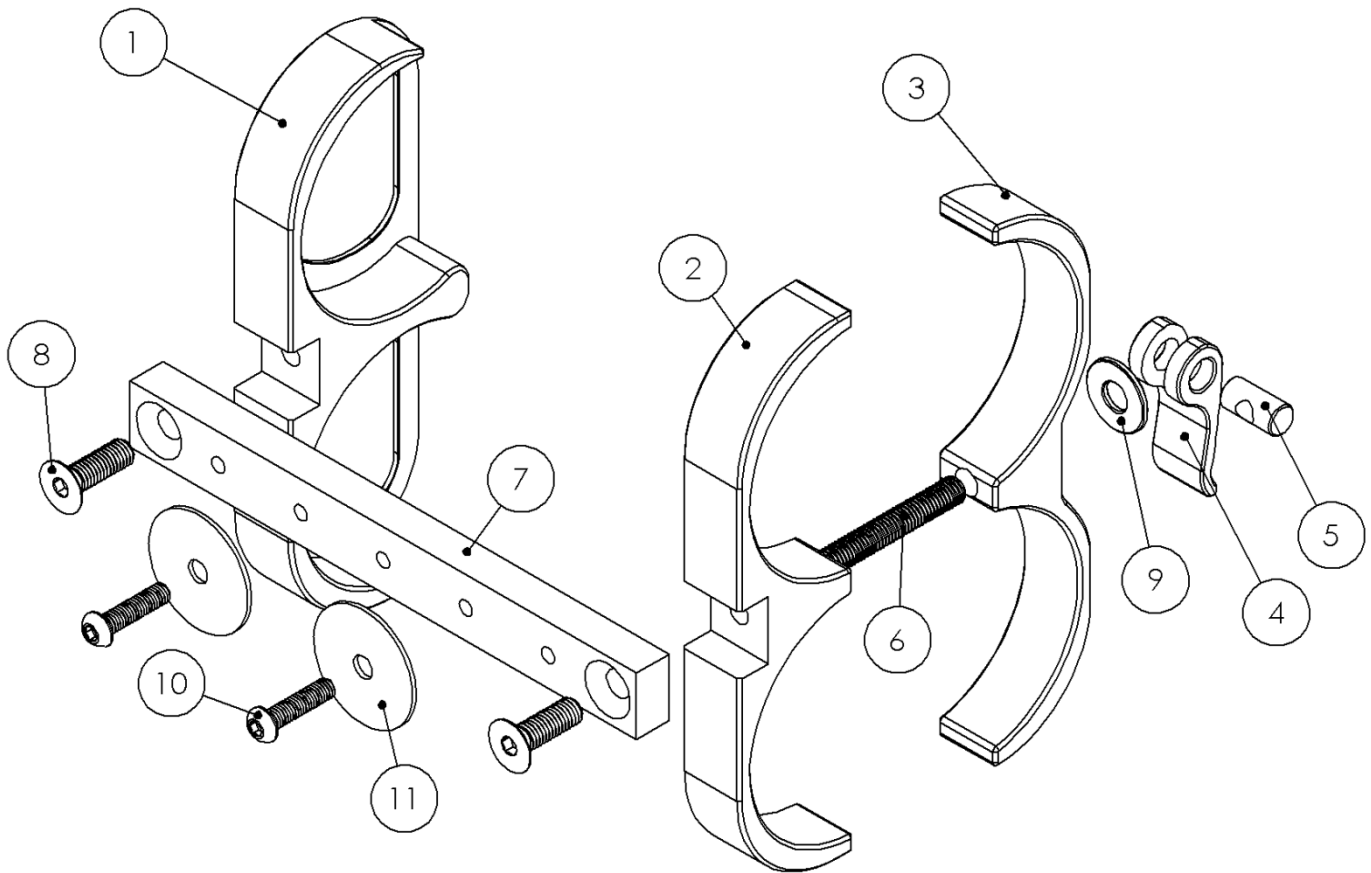

ITEM NO.	DESCRIPTION	PART NUMBER	QTY.
1	BASE BRACKET - FUEL BOTTLE MOUNT	005-0200-000014	1
2	TOP BRACKET - FUEL BOTTLE MOUNT	005-0200-000015	1
3	CLAMP - FUEL BOTTLE MOUNT	005-0200-000016	1
4	QUICK RELEASE LEVER	005-0200-000017	1
5	QUICK RELEASE NUT	005-0300-000003	1
6	SET SCREW FOR QUICK RELEASE	002-4911-308060	1
7	FSM UNIVERSAL BRACKET TYPE 1	005-0200-000019	1
8	M8X25 HEX DRIVE FLAT HEAD SCREW	002-4906-308025	2
9	QUICK RELEASE WASHER	002-5920-008002	1
10	M6X20 HEX DRIVE ROUND HEAD SCREW	002-4902-306020	2
11	FENDER WASHER M6	002-4920-006002	2

## Tools Required For Installation

- a. 5mm HEX Wrench/Key
- b. 4mm HEX Wrench/Key
- c. TBD – Additional tools required based on the installation

## Universal Installation on Any Flat Surface

Assemble the universal fuel bottle mount per the exploded diagram on the parts list using the 5mm hex wrench. Items 10 and 11 are used for installing the mount to any flat sheet surface.

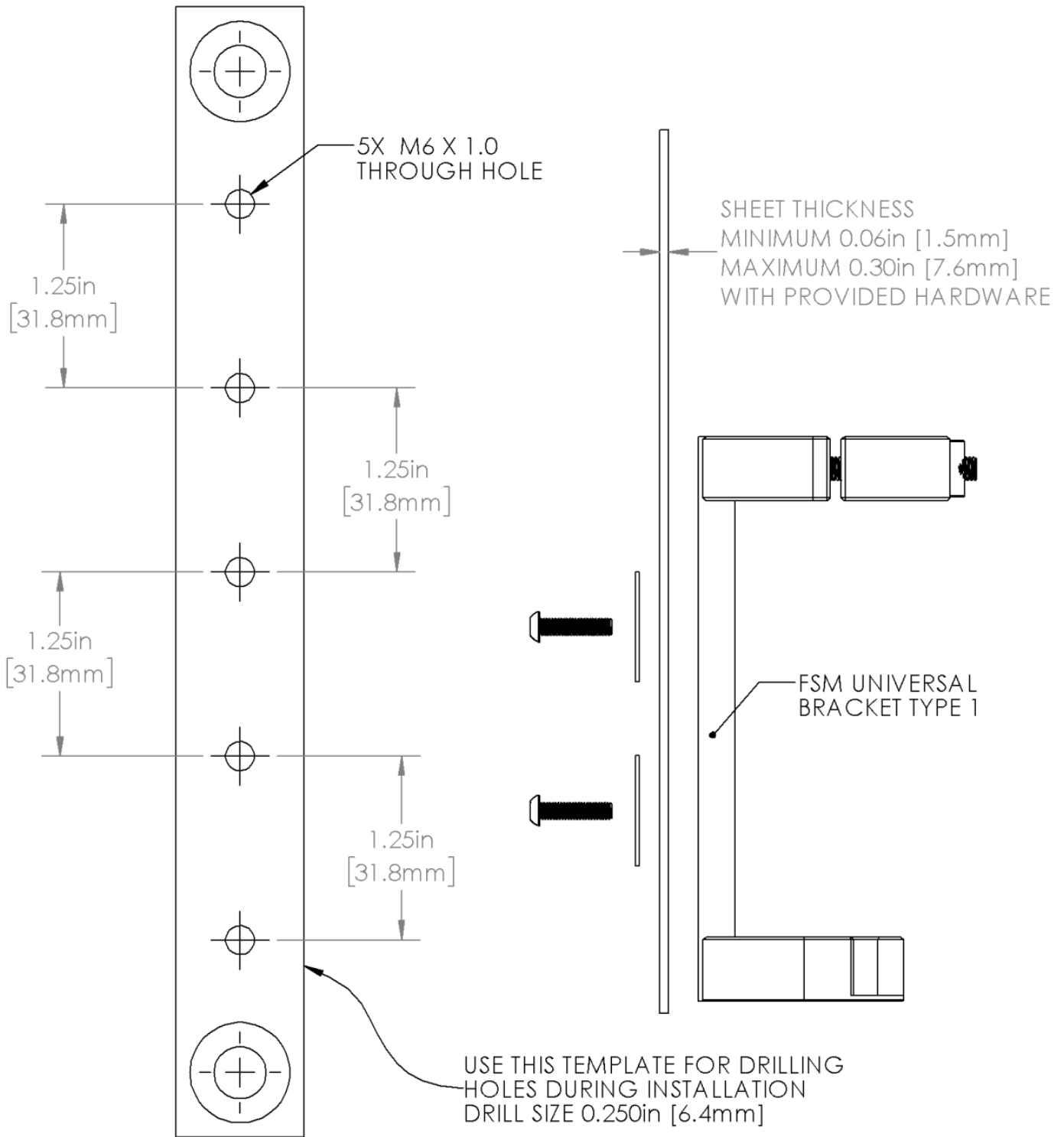

SCALE 1:1

Congratulations! You have completed the installation of the RAD MOTORWORKS UNIVERSAL MSR Fuel Bottle Storage Mount. If you have any questions or feedback regarding the installation, please feel free to contact us at [RADMotorworks@gmail.com](mailto:RADMotorworks@gmail.com) or visit our website: [www.RADMOTORWORKS.com](http://www.RADMOTORWORKS.com).

## RAD Motorworks

### TERMS OF USE, WARRANTY AND LIABILITY WAIVER

RAD Motorworks, a Washington company, having its principal place of business in Seattle, WA, USA ("RAD Motorworks") offers its motorcycle parts and accessories (the "Product") with the terms, conditions and notices as follows:

#### Terms of Use:

This Product is offered to you conditioned upon your acceptance without modification of the terms, conditions, and notices contained herein. Installation and/or use of this product implies agreement and acceptance of all such terms, conditions, and notices. If you do not agree to these terms, please do not buy the Product. If you have already bought the Product and do not agree to these terms, please return this Product promptly including the original packaging and all written materials, to RAD Motorworks.

#### Warranty Disclaimer

**You may return the product for a full refund or exchange, less any original and/or return shipping fees under the following conditions:**

1. The Product must be in 100% factory condition. Original packaging and same condition as sold – original boxes, packaging material, instructions, documentation, parts, etc.
2. The Product must be unused, unscratched, uninstalled, products will be accepted. Please do not install the Product until you are sure you want to keep it. Package items carefully in protective packaging material before returning them. Please use a proper shipping box or other suitable packaging to ensure your return or exchange is not damaged on its way back to us.

To read more about our exchanges and returns policy, please visit us at: [www.radmotorwork.com](http://www.radmotorwork.com)

With the exception of the warranties stated in the preceding paragraph, RAD Motorworks hereby disclaims all other warranties and conditions with regard to the Product including all implied warranties and conditions of merchantability and fitness for any particular purpose. There are no warranties which extend beyond the description on this agreement hereof. RAD Motorworks does not warrant against damages or defects from the installation or use of the Product. Installation instructions are provided for reference. RAD Motorworks is not responsible for any damages arising out of the installation, improper use or otherwise, of the Product. No warranty of any kind, expressed or implied, is made regarding the safety of this Product.

#### Limitation of Liability

To the extent allowed by law, RAD Motorworks shall not be held liable for any direct, indirect, incidental, punitive, special or consequential damages arising out of, or connected with, the use or misuse of this Product. Buyer/User assumes all risks and liability arising from the use of this Product.

#### Entire Agreement

This document states the entire obligation of RAD Motorworks with respect to the Product. If any part of this agreement is determined to be void, invalid, unenforceable or illegal, including, but not limited to the warranty disclaimers and liability limitations set forth above, then the remainder of the agreement shall still remain in full force and effect.

#### Governing Law

This agreement is governed by the laws of Washington, USA. You hereby consent to the exclusive jurisdiction and venue of the courts of Washington, USA, in all disputes arising out of or relating to the use of this product.